

ALL DIMENSIONS AT MINIMUM FRAME HEIGHT

\*ADJUSTABLE CASTOR ALLOWS +10.0mm [0.39in] ADJUSTMENT ON THESE DIMENSIONS

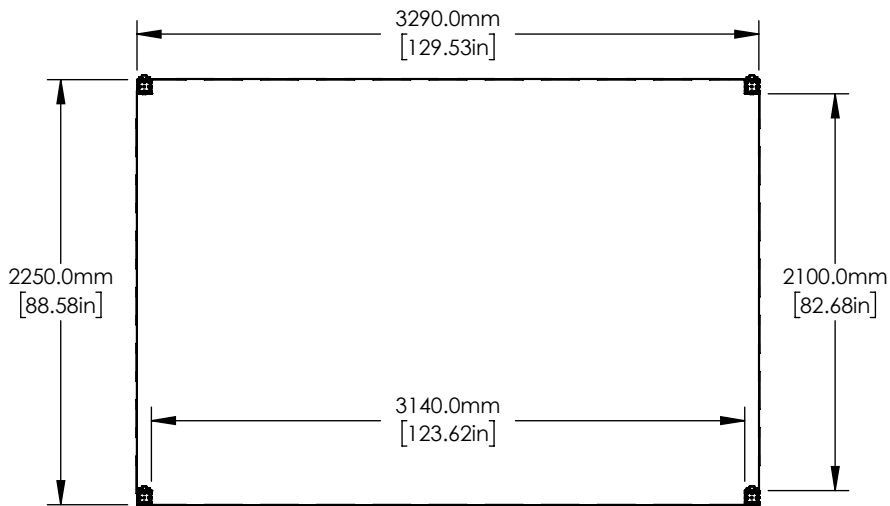

SECTION A-A

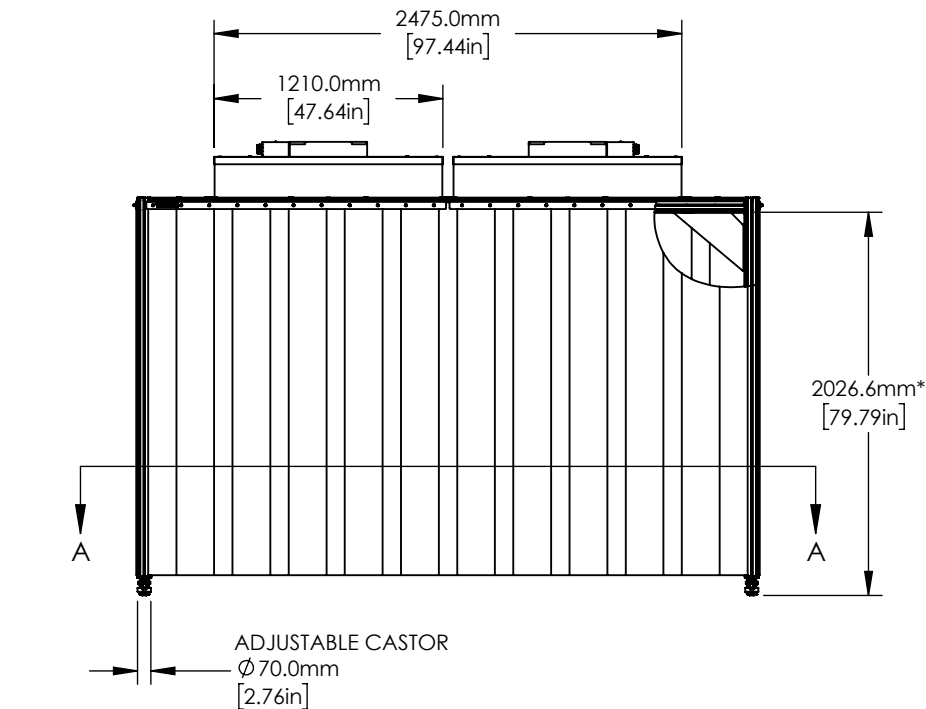

230V HEPA (H13) FAN FILTER UNIT

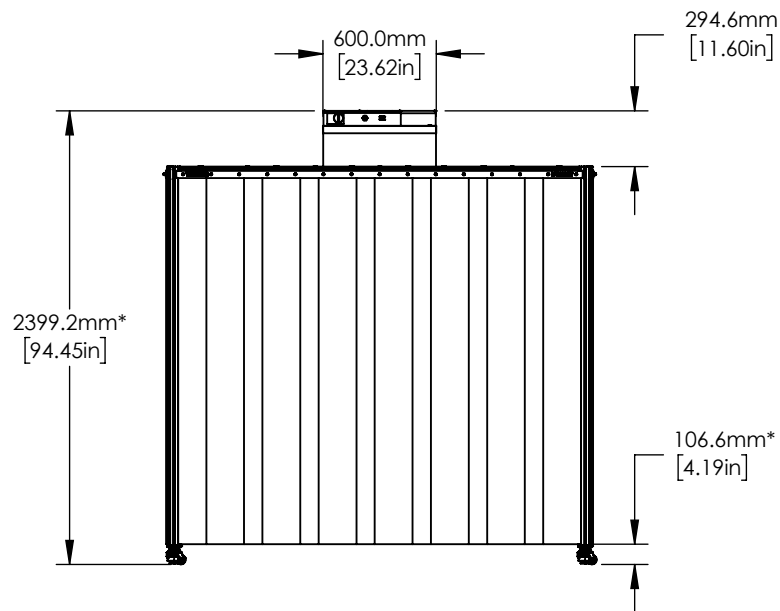
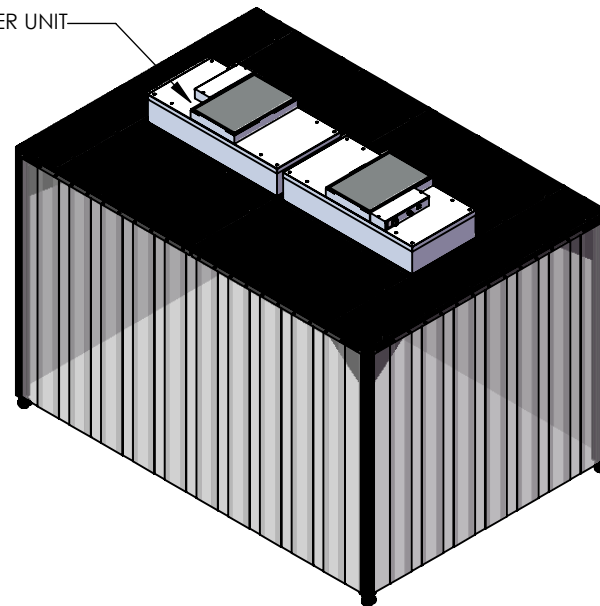

FOR INFORMATION ONLY  
NOT FOR MANUFACTURING PURPOSES

DRAWING PROJECTION			<b>THORLABS</b> www.thorlabs.com	
NAME	DATE	LAMINAR FLOW ENCLOSURE FOR 1.2 X 2.0m TABLE, WALKWAY, 230V FAN UNIT, EU PLUGS		
DRAWN TB	15/MAR/21	MATERIAL		REV A
APPROVAL SP	14/APR/21	N/A		
COPYRIGHT © 2021 BY THORLABS		ITEM #	APPROX WEIGHT	
VALUES IN PARENTHESIS ARE CALCULATED AND MAY CONTAIN ROUND OFF ERRORS		LFE1220W-EU	270 kg	