

# OBIS CellX

## The Universal Light Engine

OBIS CellX is a multi-wavelength platform for use as the laser excitation “Light Engine” in applications requiring up to 4 lasers from a single module.

CellX delivers up to four circular laser beams from a single, compact module. This includes user-adjustable steering and telescopes used to optimize the beams to your target requirements. For example, CellX can be aligned to give flexible patterns of focused stripes in a flow cytometer when used with the line-generating objective optics.

Using the same optical Cores that are at the heart of Coherent’s OBIS suite of lasers, CellX delivers best-in-class optical performance and reliability. By consolidating control, thermal management and packaging, CellX reduces complexity encountered when integrating multiple separate lasers. The savings from deleting redundant elements is reinvested into features to benefit your application.

CellX has a single electrical interface for ease of installation. Each laser wavelength can be individually controlled via RS-232 or USB computer interface, or via analog and digital control lines.

With its low cost, alignment flexibility and ease-of-integration, CellX is the universal laser Light Engine for your application.

### FEATURES & BENEFITS

- Up to 4 wavelengths
- OBIS performance
- Common power, control, and I/O interfaces
- User-adjustable beam steering and telescopes

### APPLICATIONS

- Flow Cytometry
- Microscopy
- Medical Imaging
- Optogenetics



OPTICAL SPECIFICATIONS		OBIS CellX 405	OBIS CellX 488	OBIS CellX 561	OBIS CellX 637
Wavelength <sup>1</sup> (nm)		405	488	561	637
Output Power <sup>2</sup> (mW)	Part Number				
	1426532	-	50	-	-
	1426531	-	50	-	50
	1426530	-	50	50	-
	1426529	50	50	-	-
	1318680	50	50	n/a	50
	1318682	50	50	50	50
	1318681	100	100	n/a	100
1318683	100	100	100	100	
Spatial Mode		TEM <sub>00</sub>			
M <sup>2</sup> (Beam Quality) <sup>3</sup>		≤1.3			
Beam Asymmetry (circular beam)		≤1:1.2			
Beam Diameter at 1/e <sup>2</sup> (mm)		2.6	3.0	3.5	4.5
Beam Divergence (mrad, full angle)		0.2			
Pointing Stability Over Temperature (μrad/°C)		<10			
Beam Colinearity <sup>4</sup> (μrad)		<100			
RMS Noise <sup>5</sup> (%) (20 Hz to 20 MHz)		<0.25			
Peak-to-Peak Noise <sup>5</sup> (%) (20 Hz to 20 kHz)		<1			
Long-term Power Stability (%) (8 hours, ±3°C)		<2			
Warm-up Time <sup>6</sup> (minutes) (from cold start)		<5			
Polarization Extinction Ratio		>50:1	>75:1	>50:1	>50:1
Polarization Azimuth		Vertical ±5°			
CONTROL SPECIFICATIONS					
Interface for Computer Control		USB (mini-B) and RS-232 (from DB37, 115200 Baud)			
Laser Drive Modes (Four Operating Modes, individually selected for each wavelength thru USB or RS-232)		1) CW with Power Control via USB/RS-232 2) Analog Modulation 3) Digital Modulation 4) Mixed Analog and Digital Modulation (simultaneous Analog and Digital)			
Digital Modulation					
Connection on DB37 Interface	Pin 21	Pin 4	Pin 24	Pin 7	
Voltage and Impedance	0-3.3V <sup>7</sup> , 2 kOhm input impedance each, Normally Low (off)				
Maximum Bandwidth (kHz)	50				
Rise Time (10% to 90%) (μsec)	<5				
Fall Time (90% to 10%) (μsec)	Pin 3	Pin 23	Pin 6	Pin 26	
Modulation Depth (extinction ratio)	Infinite				
Power Range	Modulate from 0% to Set Power (USB or RS-232) in Digital Mode				
Analog Modulation					
Connection on DB37 Interface					
Voltage and Impedance	0 to 5V, 2 kOhm input impedance each, Normally Low (off)				
Maximum Bandwidth, 3dB (kHz)	50				
Rise Time (10% to 90%) (μsec)	<5				
Fall Time (90% to 10%) (μsec)	<5				
Modulation Depth (extinction ratio)	>50:1, Typical 100:1				
Power Range	Modulate from 0% to 110% with 0 to 5V in Analog Mode				

<sup>1</sup> Laser-to-laser center wavelength tolerance: 405 nm ±5 nm, 488 nm and 561 nm with ±2 nm, 640 nm with 632 to 643 nm range. Short-pass filter suppression of out-of-band emission for 640 nm.

<sup>2</sup> Output power is measured at the output window of CellX. Power is variable in CW Mode from 1% (405 nm and 640 nm) to 110% of rated power. Output power is variable in CW Mode from 10% (488 nm and 561 nm) to 110% of rated power. Specifications are valid for 100% power. For 488 nm and 561 nm any residual laser emission at 808 nm fundamental is <0.1 mW.

<sup>3</sup> Beam Quality (M<sup>2</sup>) measured per laser channel using ModeMaster with 9D/10 clip levels.

<sup>4</sup> Standard alignment. User adjustable.

<sup>5</sup> RMS Noise and Peak-to-Peak Noise Specifications are per laser channel, during CW operation.

<sup>6</sup> Typical power-on delay of 1 minute from cold start.

<sup>7</sup> Digital input is 5V tolerant.

MECHANICAL AND ENVIRONMENTAL SPECIFICATIONS	OBIS CelIX
Dimensions <sup>1</sup> (mm) (L x D x H)	155 x 180 x 52.2
Beam Position from Reference <sup>1</sup> (mm)	<0.5
Beam Angle (mrad)	<5
Laser Safety Classification <sup>2</sup>	4
ESD Protection	EN61326-1 (8 kV Air Discharge, 4 kV Contact Discharge)
Baseplate Operating Temperature (°C)	10 to 45
Heat Dissipation of Laser Head <sup>3</sup> (Watts)	Typical 20, Maximum 60
Ambient Temperature <sup>4</sup> (°C)	10 to 45
Non-Operating Condition (°C)	-20 to +60
Shock Tolerance (6 ms)	30g
Weight (kg)	2.2
ELECTRICAL SPECIFICATIONS	
Power Input Connector	Use Molex 0430250600 for Power Cable Connector, Pins 1,2,3 for Power, Pins 4,5,6 for Ground
Supply Voltage (V DC)	12 ± 2 (100 Watt minimum)
Power Consumption (W)	Typical 20, Maximum 60

1 See mechanical drawing.  
 2 OEM Product - does not comply with CDRH 21CFR 1040.10 and 1040.11 without appropriate integration.  
 3 Typically 85% of heat load through the base plate. See Operator's Manual for more detail.  
 4 Non-Condensing. See Operator's Manual for more detail.

## MECHANICAL SPECIFICATIONS

### OBIS CelIX

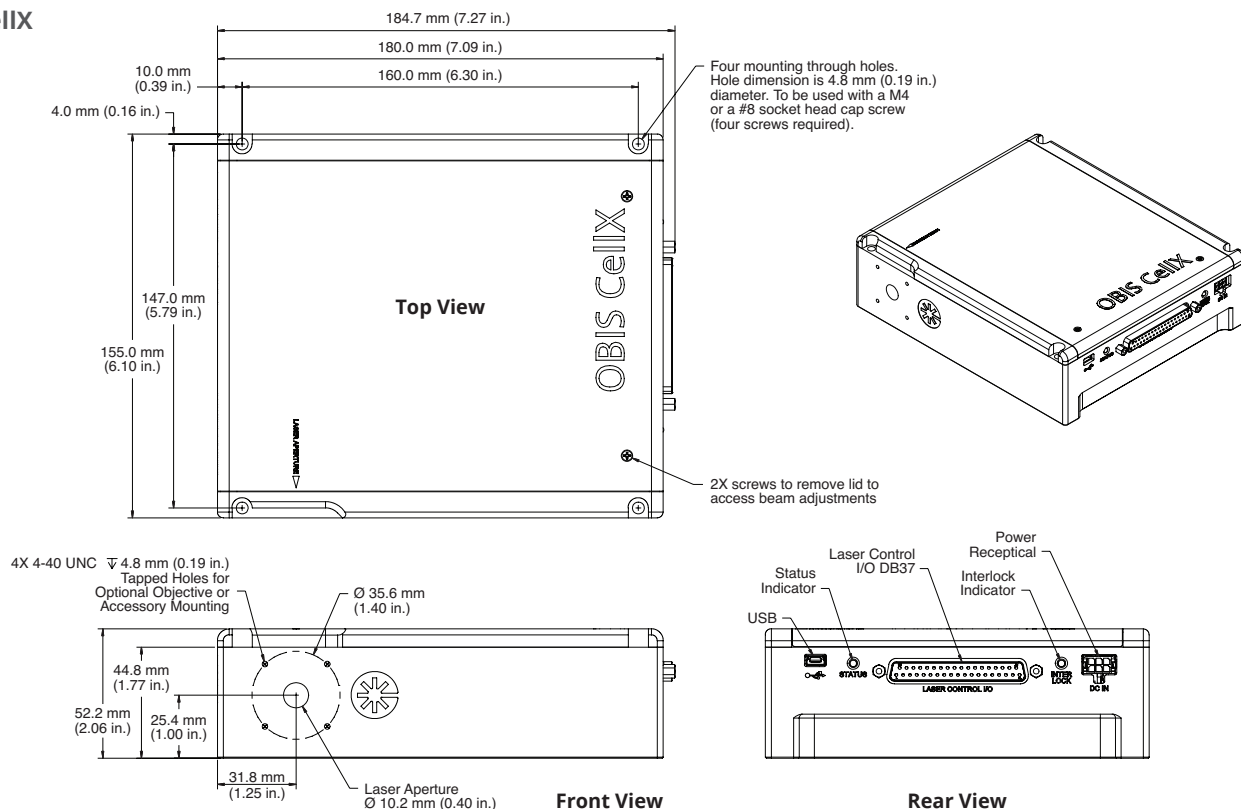

## OBIS CellX ACCESSORIES

PART NUMBER	Laser
1426532	CellX Laser 1x50 mW 488 nm
1426531	CellX Laser 2x50 mW 488, 637 nm
1426530	CellX Laser 2x50 mW 488, 561 nm
1426529	CellX Laser 2x50 mW 405, 488 nm
1318680	CellX Laser 3x50 mW 405, 488, 637 nm
1318682	CellX Laser 4x50 mW 405, 488, 561, 637 nm
1318681	CellX Laser 3x100 mW 405, 488, 637 nm
1318683	CellX Laser 4x100 mW 405, 488, 561, 637 nm
PART NUMBER	Accessory
1323532	Developer's Kit, includes CellX System 4x100 mW 405, 488, 561, 637 nm and all parts below
1321203	Accessory Kit for CellX (Alignment Tools, Interlock Plug, USB Cable, Coherent Connection, User Manual)
1365935	Accessory, Objective Lens, OL10-UV 10 $\mu$ m Focus, CellX
1383130	Accessory, Objective Lens, OL15-UV 15 $\mu$ m Focus, CellX
1321963	Accessory, Mount, Front Aperture Objective Holder, CellX
1321964	Accessory, Translation Stage with Mount for Objective Lens, CellX
1323285	Heatsink, Fan-Cooled with Stage Platform Extension, CellX
1315322	Heatsink, OEM, CellX
1299911	Accessory, Control Board, Adjustable Power, CellX
1298365	Accessory, Control Board, Key-Switch, RS-232, Digital/Analog SMB, CellX
1313160	Accessory, Interlock Plug, DB37, CellX
1323597	Accessory, Control Board, 4 Analog Modulation Inputs, RS-232
1211389	Power Supply, OBIS for 6L Remote, CellX, Laser Box



## OBIS CellX ACCESSORIES

OPTICAL PERFORMANCE SPECIFICATIONS	OBIS CellX Objective Lens Accessories	
	OL10-UV	OL15-UV
Part Number	1365935	1383130
Wavelength Range (nm)	345 to 700	
Beam Profile at Focus	Gaussian Profile on both the Vertical and Horizontal Axis	
Focus Spot Size Vertical ( $\mu\text{m}$ ) ( $1/e^2$ )	10 $\pm$ 2	15 $\pm$ 3
Focus Spot Size Horizontal <sup>1</sup> ( $\mu\text{m}$ ) ( $1/e^2$ )	60 $\pm$ 15	90 $\pm$ 20
Working Distance <sup>2</sup> (mm)	36.4	60.9
Dimensions (mm)	22 x 22 x 47.2	22 x 22 x 59.7
Vertical Adjustment <sup>3,4</sup> ( $\mu\text{m}$ )	$\pm$ 250	
Horizontal Adjustment <sup>3,4</sup> ( $\mu\text{m}$ )	$\pm$ 250	
Focus Adjustment <sup>5</sup>	Independent focus adjustment of all wavelengths	

- 1 Measured at location of best vertical focus. System aligned to lower limit on delivery. Horizontal beam size can be adjusted up to the upper limit. System may be adjusted to reduce or expand the horizontal focus width. See Operator's Manual.
- 2 Measured from mechanical surface (output end) of the objective assembly - see drawing.
- 3 Measured from nominal beam axis. Adjustment using tilt/yaw adjustment internal to CellX, while meeting all optical specifications.
- 4 Assumes the objective assembly mounted within less than 200 mm (optical path length) from the output face of CellX.
- 5 Adjustment using telescope adjustment internal to CellX, while meeting all optical specifications.

## NOMINAL OPTICAL PERFORMANCE

Nominal Optical Performance Through Focus OL10-UV

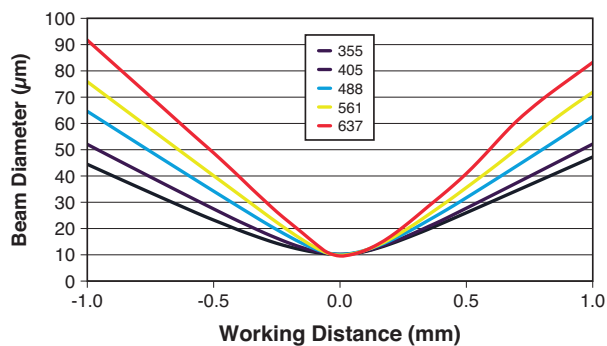



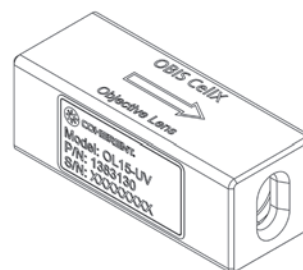
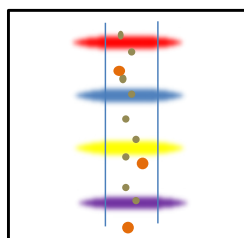
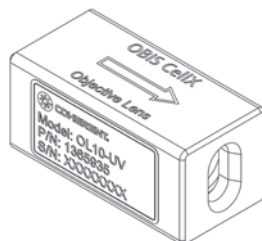
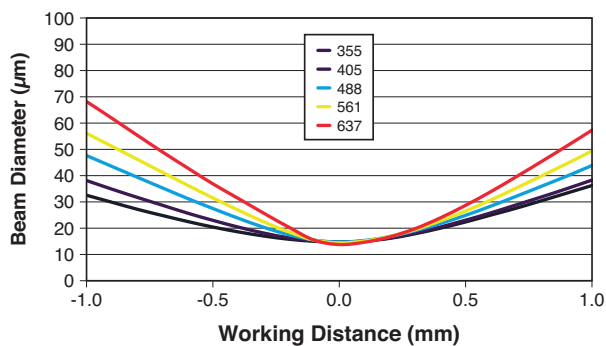

Nominal Optical Performance Through Focus OL15-UV



Flow Cytometry Example:  
Four Laser Focus with Separated  
Positions (user-adjustable)

	Name	Part Number	Description
	CellX Accessory Kit, Interlock Plug	1321203	Alignment Tools, Interlock Plug, USB Cable, Coherent Connection Software, Operator's Manual
	CellX Control Board, Analog Modulation, RS-232	1323597	Control Board for OBIS CellX, DB37 with four Analog Modulation Inputs and RS-232 communication
	CellX Control Board, Adjustable Power	1299911	Control Board for OBIS CellX with four laser output power adjustment knobs
	CellX Control Board, Key Switch, RS-232, Digital and Analog Modulation	1298365	Control Board for OBIS CellX with Key Switch, Interlock, RS-232, Four Analog Modulation inputs and Four Digital Modulation inputs
	CellX Mount for Objective Lens	1321963	Mounting kit to mount the Objective Lens to the OBIS CellX
	CellX Objective Lens, OL10-UV, 10 µm Focus	1365935	OBIS CellX Objective Lens to create a focus of 10 x 60 µm at a distance of 36.4 mm

	Name	Part Number	Description
	CellX Objective Lens, OL15-UV, 15 µm Focus	1383130	OBIS CellX Objective Lens to create a focus of 15 x 90 µm at a distance of 60.9 mm
	CellX Translation Stage with Mount for Objective Lens	1321964	Mount and Stage to translate the OBIS CellX Objective Lens to optimize the focus location
	CellX Heatsink, Fan Cooled with Platform Extension	1323285	OBIS CellX Heatsink with cooling fans and platform extension for Objective Lens stage
	CellX Heatsink, OEM	1315322	OBIS CellX compact heatsink, OEM version. Requires hole in mounting plate to allow heatsink to protrude through the optics deck and requires that the OEM provide air flow.



Coherent, Inc.,  
 5100 Patrick Henry Drive Santa Clara, CA 95054  
 p. (800) 527-3786 | (408) 764-4983  
 f. (408) 764-4646

[tech.sales@coherent.com](mailto:tech.sales@coherent.com) [www.coherent.com](http://www.coherent.com)

Coherent follows a policy of continuous product improvement. Specifications are subject to change without notice. Coherent's scientific and industrial lasers are certified to comply with the Federal Regulations (21 CFR Subchapter J) as administered by the Center for Devices and Radiological Health on all systems ordered for shipment after August 2, 1976.

Coherent offers a limited warranty for all OBIS CellX Lasers. For full details of this warranty coverage, please refer to the Service section at [www.coherent.com](http://www.coherent.com) or contact your local Sales or Service Representative.  
 MC-002-17-0M0821Rev.D Copyright ©2021 Coherent, Inc.