

HORIBA
Scientific

partica 

Laser scattering particle size distribution analyzer LA-960 Series



HORIBA proudly introduces the newest breakthrough in particle size technology.

Laser Scattering Particle Size Distribution Analyzer Partica LA-960

This latest evolution in the LA series advances scientific knowledge for tomorrow's world through intuitive software, unique accessories, and high performance.

The LA-960 continues HORIBA's proud tradition of leading the industry with innovative design.



partica 



HORIBA's Original Optical Design

HORIBA's ground breaking optical design perfects the static light scattering particle sizing technique.

Advanced Detector Design

The number of detectors, angular range, and layout each contribute to overall system performance. The LA-960 uses 87 logarithmically spaced silicon photodiode detectors covering a range of 0.006 - 165.7 degrees to measure complete particle size distributions.

Automatic Laser Alignment in Seconds

Always make perfect measurements with computer-controlled laser alignment. The alignment process is finished in only a few seconds with HORIBA's innovative approach.

Superior Instrument-to-Instrument Precision

The LA-960 is designed and built to provide the same experience regardless of manufacture date, operator skill, or geographic location. Achieve unmatched instrument agreement without the hassle of correlation.

Guaranteed Accuracy and Precision

The LA-960 is a highly refined particle size analyzer capable of accurately measuring NIST-traceable size standards within 0.6% of specification. Fully compliant with ISO 13320 recommendations regarding the measurement of materials on the D10, D50, and D90.

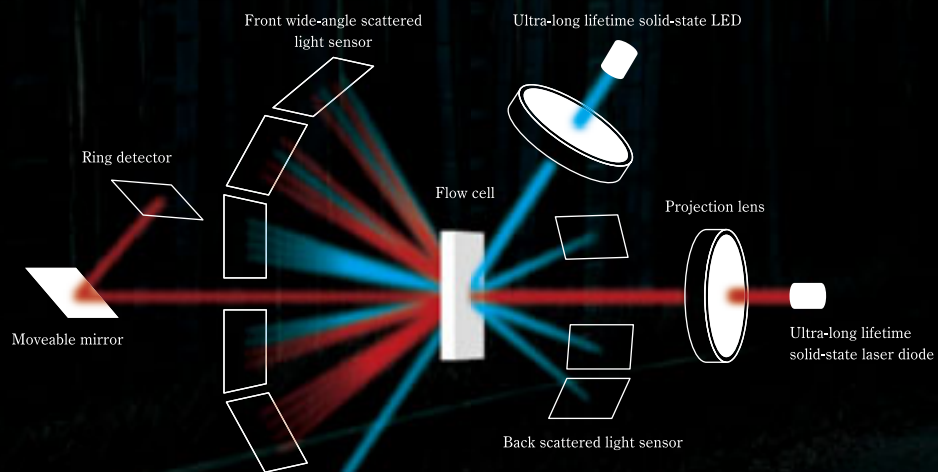

Measuring with two light sources, red laser diode and blue LED, which enables detection from nanometers to millimeters with a single optical setup.

Superior nanoparticle detection using red and blue light sources

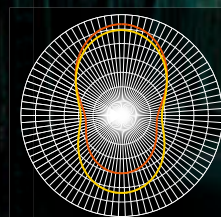

— 0.05 μm 405 nm
— 0.07 μm 405 nm



— 0.05 μm 650 nm
— 0.07 μm 650 nm

Accessories

MiniFlow Circulation System



Feature

The MiniFlow minimizes sample and dispersant amounts. This miniaturized circulation system features fill and circulation pumps, ultrasonic probe, and drain valve for fully automated operation.

Typical Applications

Precious samples requiring powerful dispersion
Materials requiring hazardous dispersants
Size range: 10nm - 1000 μm

Fraction Cell



Feature

The Fraction Cell makes measurements with only micrograms of sample. This unique accessory is available in 5, 10, and 15 mL volumes and is fully solvent resistant.

Typical Applications

Precious samples requiring minimal dispersion
Drug discovery
Cost-conscious users

Paste Cell



Feature

The Paste Cell measures samples which cannot be diluted or which are dispersed in a viscous medium. This unique accessory measures particle size without changing dispersion conditions.

Typical Applications

Inks
Carbons
Creams
Magnetic samples

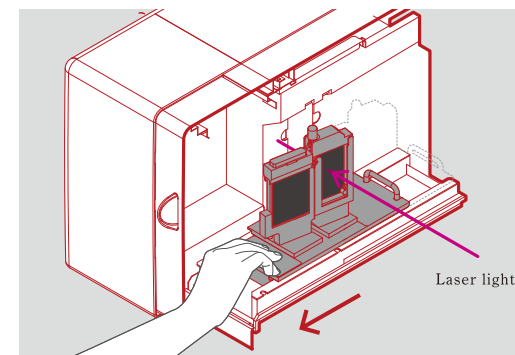

State of the Art Sampling Systems

Dry Measurement

Automated, powerful dry powder dispersion

The LA-960 Powderjet combines several unique and patented features to provide the most reproducible dry measurements. Use the Auto Measurement function to control vacuum, air pressure, powder flow, start/stop conditions, measurement duration, and data processing. Designed to handle every application including small sample amounts, friable powders, and highly agglomerated materials.

● Smart Scans - Trigger function

This function allows for very precious materials to be measured accurately. When the sample amount is limited or low flow ability, the Trigger functions perfectly start and stop the measurement.

● Self-Adjusting Powder Flow

Historically, the biggest challenge in dry powder measurement involved establishing an even powder flow. The LA-960 Powderjet has solved that challenge with a self-adjusting feedback loop to maintain a constant laser transmittance. This is a crucial factor in creating reliable, reproducible dry powder size measurements.



Wet Measurement

Sample-to-sample analysis in less than 60 seconds

The HORIBA LA-960 wet circulation system is an easy, fast and very powerful dispersion system. The standard wet system offers a full package of a dispersant fill pump, liquid level sensor, circulation pump, 30 W in-line ultrasonic probe, and drain valve, which is all software-controlled for true one-button operation. This advanced design provides highly reproducible particle size results.

Auto-fill Auto-fill pump → Flow cell → Sample bath

Circulation Sample bath → Ultrasonic probe → Flow cell

Drain Flow cell → Sample bath → Drain

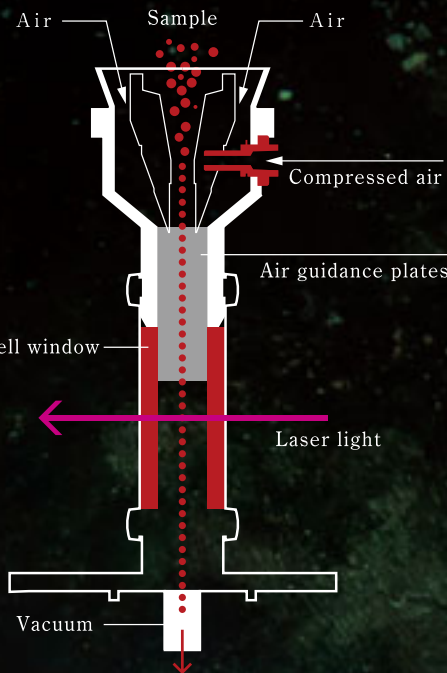
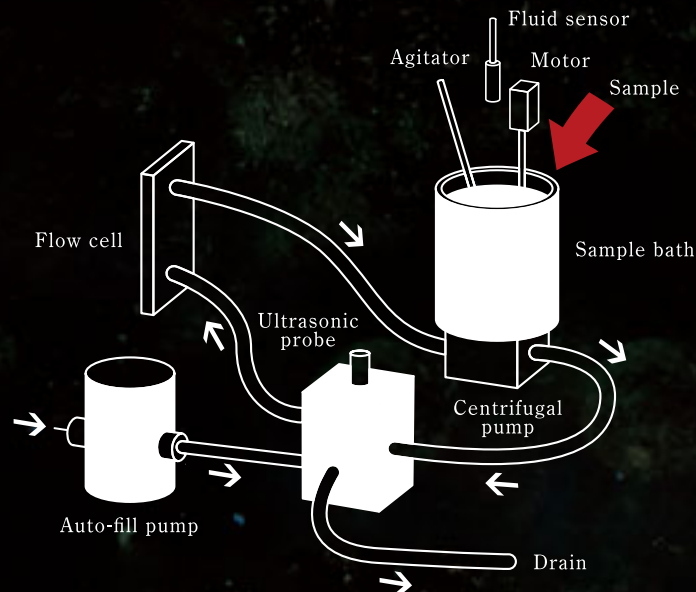

● Available chutes

● **Standard chute**
Equipped with every PowderJet Dry Feeder and used for most powders.



● **V type chute**
This chute is ideal for both small amounts of powder and powder which does not flow easily, e.g. magnetic powders.

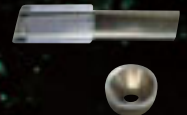

● **Coated chute**
This coated chute is useful for samples which adhere to the stainless steel standard chute.



● **Vacuum sampler**
This accessory is useful for measuring very small amounts of powder.
*Sampling table is included.



Laser scattering particle size distribution analyzer Model: LA-960

Measurement Principle	Mie scattering and Fraunhofer diffraction
Measurement range	10 nm - 5000 μ m
Measurement Time	Typical measurement takes 60 seconds from liquid filling, sampling and measurement to rinsing.
Measurement method	Circulation measurement or fraction cell measurement (Fraction cell is optional)
Sample Quantity	Approximately 10 mg - 5 g (Depending on the particle size, distribution and density)
Dispersing Volume	Approximately 180 mL for standard pumping system, 5/10/15 mL for FractionCell accessory, Manual filling : 35 mL, Automatic filling : 40 mL for MiniFlow accessory. Approximately 1 L of LiterFlow option.
Available carrier fluid	Aqua* (A type), Organic solvent (S type) (*Ethanol can be used as a dispersing additive)
Communication	USB 2.0
Light Sources	Red solid state 5 mW laser diode (650 nm), Blue solid state 3 mW LED (405 nm)
Dispersion System	In-line ultrasonic probe: 30 W, 20 kHz, adjustable levels Circulation pump: Fully automated fill and circulation pumps, 15 adjustable speeds, 4 selectable fill levels, 15 selectable circulation speeds (max: 10 L/min)
Operating Conditions	15~35°C (59 to 95°F), relative humidity 85% or less (no condensation)
Power	AC100/120/230V 50/60Hz, 300V A
Dimensions	705 (W) ×565 (D) ×500 (H) mm
Mass	56kg
Computer Requirements	PC operation, Software compatible with Windows* 7 32-bit and 64-bit environments, *contact HORIBA for additional operating system compatibilities

*Windows is a registered trademark of Microsoft Corporation in the United States and other countries.

External Dimensions (mm)

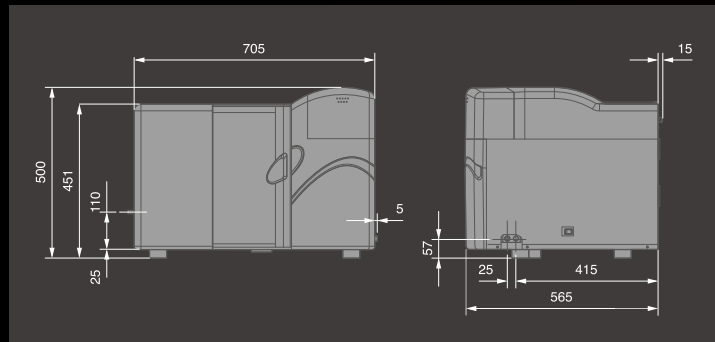

Class 1 Laser Product

*Laser Particle Size Distribution Analyzer LA-960 Standard Model

Powderjet Dry Feeder Accessory

Dispersion Method	Compressed air dispersion using Venturi nozzle
Sample Delivery	Vibrating feeder
Sample Disposal	Vacuum-driven evacuation
Measurement range	100 nm - 5000 μ m
Controls	Communication: Serial cable to LA-960 main unit Measurement: Vibrating feeder controlled automatically via feedback or manually by user, Vacuum AUTO/OFF, Compressed Air AUTO/OFF, Air pressure adjustable from 0 - 0.4 MPa in 40 steps
Measurement Time	Typical measurement takes 2 seconds or longer.
Operating Conditions for PowderJet	15~35°C (59 to 95°F), relative humidity 85% or less (no condensation)
Dimensions	332 (W) ×321 (D) ×244 (H) mm (not including dimensions of projections and LA-960 measurement unit)
Power for PowderJet Operation	AC100V, 120V, 230V, 50 or 60Hz, 1500VA (Including vacuum but LA-960 measurement unit)
Compressed Air Supply Pressure	Compressed air supply origin pressure: 0.4 - 0.8 MPa Compressed air controlling range: 0.01 - 0.4 MPa
Compressed Air Connection	Quick connector for resin tube with 6mm outer diameter (Compressed air supply equipment must be provided separately)
Remarks	Vacuum is equipped as standard

*When ordering the PowderJet, please specify the power requirements for the final destination.

*Above specifications and functionality are valid only when PowderJet is installed on the LA-960 main unit and controlled using the LA-960 software.

*Manufacturers and models indicated for vacuum, air compressor, computer, monitor, and/or printer are subject to change.

◎Air Compressor

Inlet pressure within 0.5 - 0.8 MPa, Tank capacity 26 L or larger, Flow rate 45 L/min or faster

External Dimensions (mm)



Class 1 Laser Product

*Laser Particle Size Distribution Analyzer LA-960 Model with Dry Unit Accessory

Solving a vast array of application issues

Pharmaceutical



The size of particles greatly influences several factors such as dissolution rate, dosing, bioavailability, and immunotoxicity, making it an essential parameter for pharmaceutical and biotechnology applications. From simple inhalers to advanced chemotherapies, particle size affects treatment efficacy.

Functional polymers



The performance of plastics, such as PET is determined by the molecular weight (i.e., size) of the polymers used to prepare the material. The same sort of analysis is also critical for sealants and adhesives.

Energy



Particle size influences both capacity and coulombic efficiency of battery electrode materials. The electrical behavior of materials such as the lithium electrodes is predicted by size analysis.

Pigments



Particle size analysis is used to evaluate new formulations, characterize raw materials, and perform product quality tests. The ink used in inkjet printers requires excellent particle sizing to ensure its correct application to paper without blurring or smudging.

Paper



A number of additives are incorporated in the papermaking process. From calcium carbonate, which is used as filler, to a variety of minerals and latex added to the surface coatings to improve brightness, gloss and printability; they all require particle sizing.

Minerals



Minerals are used in many industries, including construction, fracking and abrasives. In all cases, the performance of the minerals is dependent on the size and shape of the particles.

Innovations in hardware and software



State of the art nanoparticle measurement

Performance

The advanced design of the LA-960 allows for easy measurement of nanoparticle applications. NIST-traceable size standards verify that the LA-960 accurately measures peaks as fine as 30 nanometers.



Overlay of 30, 40, 50, and 70 nanometer results



60 - second measurement cycle, even in wet mode

Speed

This incredible speed is made possible by automatic laser alignment, fully automated liquid handling, and intuitive software design.

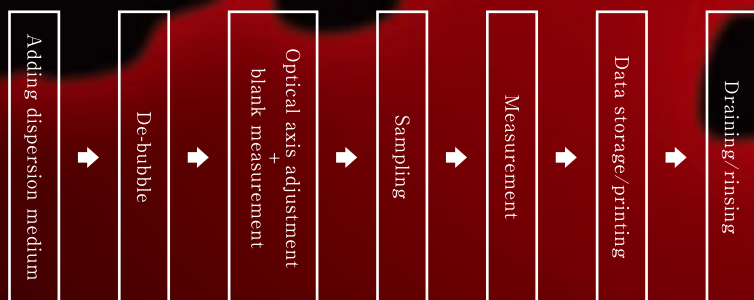

Measurement range 10 nm - 5,000 um

Wide range

The LA-960 features a wide measurement range to measure every application. The unique optical bench is user-friendly and standard in every LA-960 configuration.



Method Expert

Operation

The LA-960 Method Expert software makes it easy to create robust, powerful methods for research and development purposes and quality control. The Method Expert is a series of guided, automated tests with advice to help the user choose values for refractive index, concentration, ultrasonic dispersion, pump speed, and measurement duration. Without any training, users can generate effective data in a short amount of time using the software.

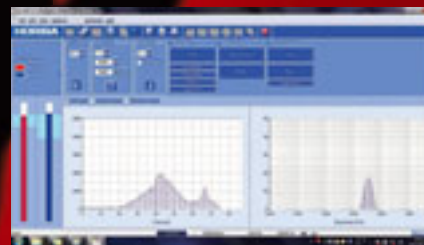

Measurement Screen
Real-time display of the measurement result



The Method Expert recommends the most suitable refractive index.

Data correlation support

Correlation to historic data is an increasingly important factor when choosing a new particle size analyzer. The LA-960 provides full backwards compatibility with the LA-950 and an intelligent correlation software to the LA-920/930 series. Correlation to other instruments is often possible with assistance of HORIBA's applications and technical support experts.

HORIBA Global Network

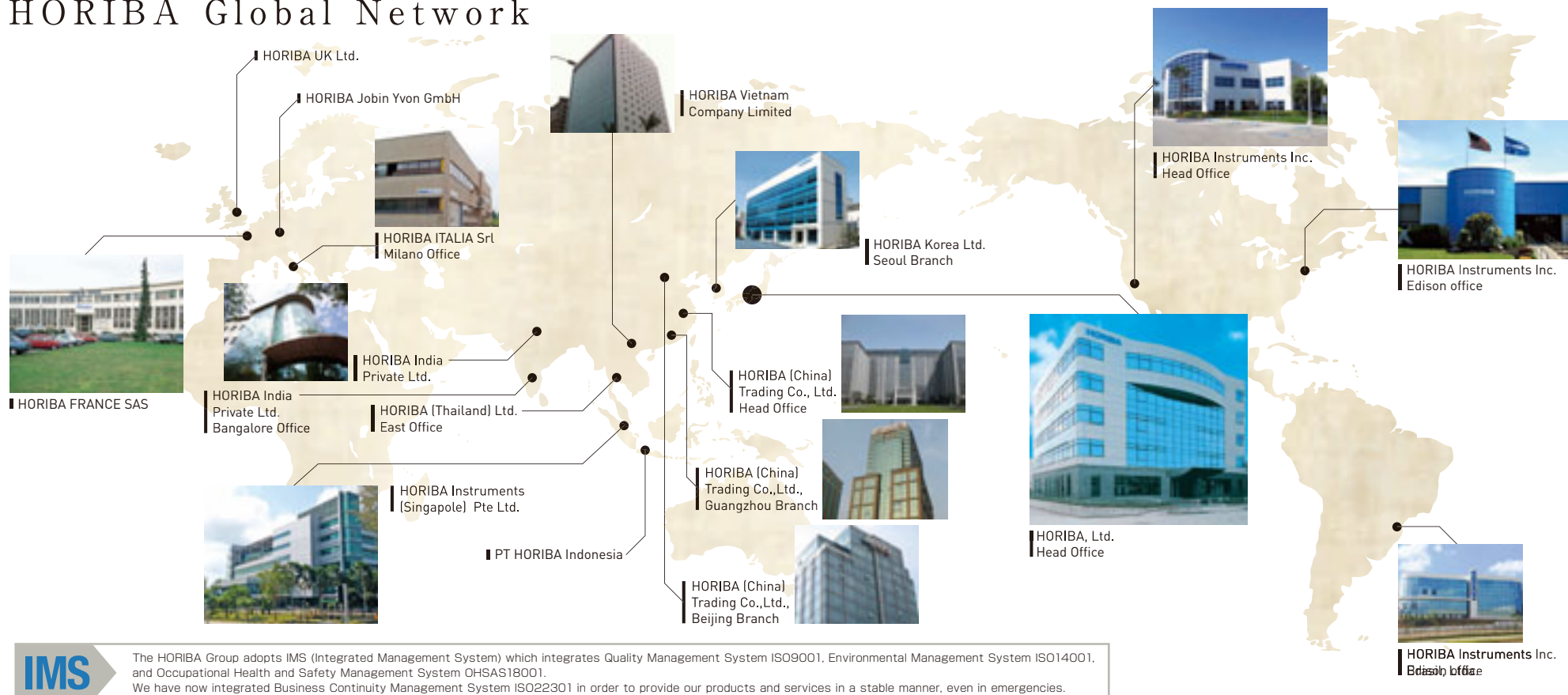

IMS

The HORIBA Group adopts IMS (Integrated Management System) which integrates Quality Management System ISO9001, Environmental Management System ISO14001, and Occupational Health and Safety Management System OHSAS18001. We have now integrated Business Continuity Management System ISO22301 in order to provide our products and services in a stable manner, even in emergencies.



Please read the operation manual before using this product to assure safe and proper handling of the product.

- The specifications, appearance or other aspects of products in this catalog are subject to change without notice.
- Please contact us with enquiries concerning further details on the products in this catalog.
- The color of the actual products may differ from the color pictured in this catalog due to printing limitations.
- It is strictly forbidden to copy the content of this catalog in part or in full.
- The screen displays shown on products in this catalog have been inserted into the photographs through compositing.
- All brand names, product names and service names in this catalog are trademarks or registered trademarks of their respective companies.

<http://www.horiba.com> e-mail: info@horiba.co.jp

HORIBA, Ltd. **Japan**
Head Office
 2 Miyano Higashi, Kisshoin, Minami-ku, Kyoto, Japan
 Phone: 81 (75) 313-8123 Fax: 81 (75) 321-5725

HORIBA (China) Trading Co., Ltd. **China**
 Unit D, 1F, Building A, Synnex International Park, 1068 West Tianshan Road, Shanghai, 200335, China
 Phone: 86 (21) 6289-6060 Fax: 86 (21) 6289-5553
Beijing Branch
 12F, Metropolis Tower, No.2, Haidian Dong 3 Street, Beijing, 100080, China
 Phone: 86 (10) 8567-9966 Fax: 86 (10) 8567-9066
Guangzhou Branch
 Room 1611 / 1612, Goldlion Digital Network Center, 138 Tiyu Road East, Guangzhou, 510620, China
 Phone: 86 (20) 3878-1883 Fax: 86 (20) 3878-1810

HORIBA Instruments (Singapore) Pte Ltd. **Singapore**
 3 Changi Business Park Vista #01-01, Akzonobel House, Singapore 486051
 Phone: 65 (6) 745-8300 Fax: 65 (6) 745-8155

HORIBA KOREA Ltd. **Korea**
Seoul Branch
 10, Dogok-Ro, 6-Gil, Gangnam-Gu, Seoul-Si, 06259, Korea
 Phone: 82 (2) 753-7911 Fax: 82 (2) 756-4972

HORIBA India Private Limited **India**
 246, Okhla Industrial Estate, Phase 3 New Delhi-110020, India
 Phone: 91 (11) 4646-5000 Fax: 91 (11) 4646-5020
Bangalore Office
 No.55, 12th Main, Behind BDA Complex, 6th sector, HSR Layout, Bangalore South, Bangalore-560102, India
 Phone: 91 (80) 4127-3637

HORIBA Vietnam Co., Ltd. **Vietnam**
 Unit 6, 10 Floor, CMC Tower, Duy Tan Street, Dich Vong Hau Ward, Cau Giay District, Hanoi, Vietnam
 Phone: 84 (24) 3795-8552 Fax: 84 (24) 3795-8553

PT HORIBA Indonesia **Indonesia**
 Jl. Jalur Sutera Blok 20A, No.16-17, Kel. Kunciran, Kec. Pinang Tangerang-15144, Indonesia
 Phone: 62 (21) 3044-8525 Fax: 62 (21) 3044-8521

HORIBA Instruments Incorporated **USA**
 9755 Research Drive, Irvine, CA 92618, U.S.A.
 Phone: 1 (949) 250-4811 Fax: 1 (949) 250-0924
Edison Office
 3880 Park Avenue, Edison, NJ 08820, U.S.A.
 Phone: 1 (732) 494-8660 Fax: 1 (732) 549-5125

HORIBA Instruments Brasil, Ltda. **Brazil**
 Rua: Presbitero Plinio Alves de Souza, 645, Loteamento Polo Multivias Barirro Medeiros-Jundiai Sao Paulo-CEP 13.212-181 Brazil
 Phone: 55 (11) 2923-5400 Fax: 55 (11) 2923-5490

HORIBA (Thailand) Limited **Thailand**
 393, 395, 397, 399, 401, 403 Latya Road, Somdetchaopraya, Klongsan, Bangkok, 10600, Thailand
 Phone: 66 (0) 2-861-5995 ext.123 Fax: 66 (0) 2-861-5200
East Office
 850 / 7 Soi Lat Krabang 30 / 5, Lat Krabang Road, Lat Krabang, Bangkok 10520, Thailand
 Phone: 66 (0) 2-734-4434 Fax: 66 (0) 2-734-4438

HORIBA FRANCE SAS **France**
 16-18, rue du Canal, 91165, Longjumeau Cedex, France
 Phone: 33 (1) 69-74-72-00 Fax: 33 (1) 69-09-07-21

HORIBA Jobin Yvon GmbH **Germany**
 Neuhoferstrasse 9, D. 64625, Bensheim, Germany
 Phone: 49 (89) 62-51-84-750 Fax: 49 (89) 62-51-84-7520

HORIBA ITALIA SRL **Italy**
 Via Luca Gaurico 209-00143, Roma, Italy
 Phone: 39 (6) 51-59-22-1 Fax: 39 (6) 51-96-43-34

HORIBA UK Limited **UK**
Northampton Office
 Kyoto Close Moulton Park, Northampton NN3 6FL, UK
 Phone: 44 (1604) 542-500 Fax: 44 (1604) 542-699



HORIBA
Scientific