

## ELCOMAT<sup>®</sup> vario N - Product Line

Electronic Autocollimator

# ELCOMAT® vario N Electronic Autocollimator

Autocollimators are optical measuring instruments that can measure the smallest changes in the angular position of optical reflectors. With electronic autocollimators, the autocollimation image is detected using CCD lines or matrix-sensors.

Electronic autocollimators are primarily used for the following measuring tasks:

- Measurement of smallest angular deviations
- Ultra-precise angle adjustment and calibration
- Quality control of machine tools and its components
- Assembly automation
- Angular position monitoring

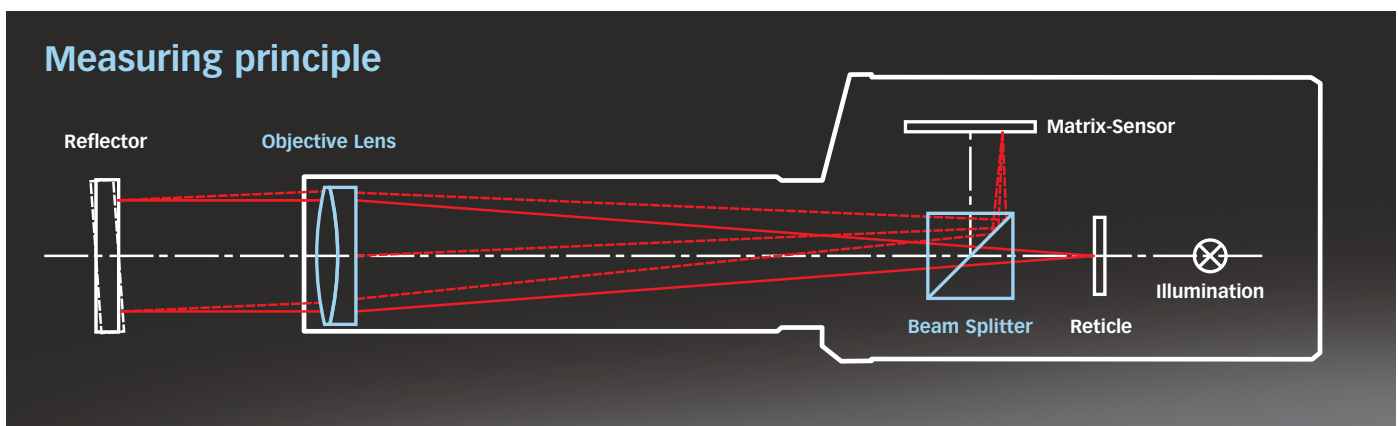
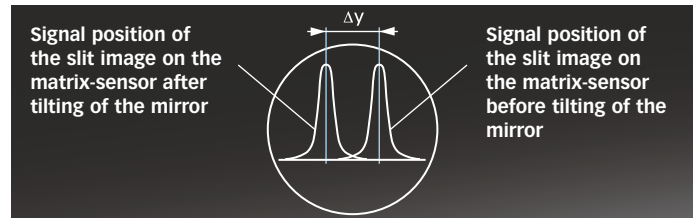

## Typical Applications of the Autocollimator

### Machine Tool Industry

- Measurement of the straightness of machine beds and guideways
- Measurement of position uncertainty of rotary and indexing tables
- Measurement of flatness of granite tables, measuring and leveling plates
- Measurement of parallelism of guideways
- Measurement of the squareness of 90° stone angle standard, guideways etc.

### Optical, Laser and Semiconductor Industry

- Adjustment of reflectors
- Angular position monitoring

### Calibration Institutes

- Calibration of autocollimators and polygon mirrors

### Research Facilities

- Measurement of smallest angle deviations
- Long-term analyses of mechanical alignment units
- Adjustment of mirrors in optical set-ups
- Use in education

## Measuring Range and Measuring Distance

The measuring range of any autocollimator decreases as the measuring distance increases. The measuring accuracy of autocollimation telescopes is independent of the distance under negation of environmental influences. With the autocollimators of the ELCOMAT® product line the measuring range is constant up to a certain measuring distance and then decreases as the distance between the autocollimator and the mirror

increases. The typical measuring range at different distances is listed in the technical specifications of the ELCOMAT® vario N product line.

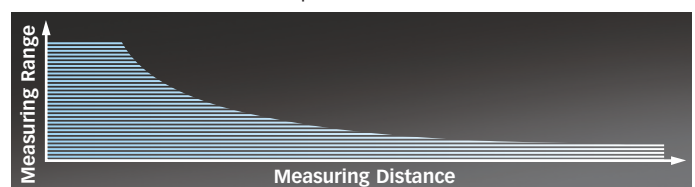

## Components of the New ELCOMAT® vario N

### Autocollimation Sensor Head

In the autocollimation sensor head, the reticle pattern reflected by an optical mirror is imaged on a corresponding matrix sensor, digitized and its position change is evaluated. The direct digital signal processing in the sensor head guarantees an excellent signal-to-noise ratio. Additional position sensors in the head enable the autocollimator to be adjusted easily, quickly and precisely. The measuring frequency of the measuring sensor is approx. 30 Hz.

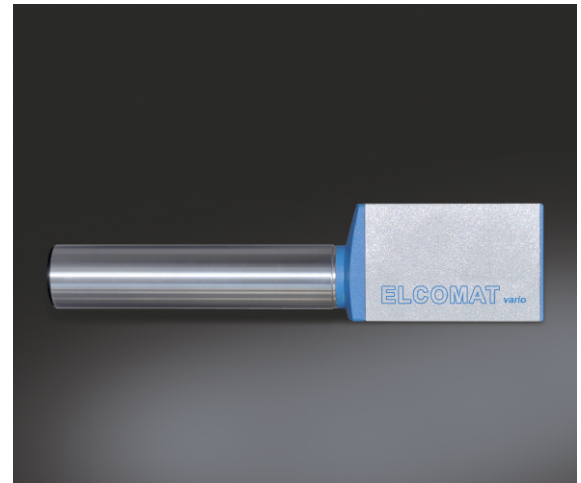

### Display Unit

The intelligent display module is essential for the operation of the autocollimator and functions as a digital control and output unit. The integrated software, designed for maximum user-friendliness, allows the autocollimator to operate fully independently of a PC/laptop. The extensive software functions are self-explanatory and easy to use even for unexperienced personnel.

A standard PC/laptop can also be connected to the display unit via the integrated USB interface. The interface protocol is compatible with the text protocol of the ELCOMAT® 3000/HR and the ELCOMAT® vario predecessor product line.



### Transportation Case

The transport case (included in the scope of delivery) offers space for the following accessories:

#### In Scope of Delivery:

- Power supply
- IR remote control
- RS-232 cable
- USB cable
- Software INCOLINK

#### Optional:

- Adjustable holder
- Laser attachment
- Base mirror, complete
- Magnetic base
- Software ELCOWIN/RTM



# ELCOMAT® vario N

## Dimensions of the Different ELCOMAT® vario N

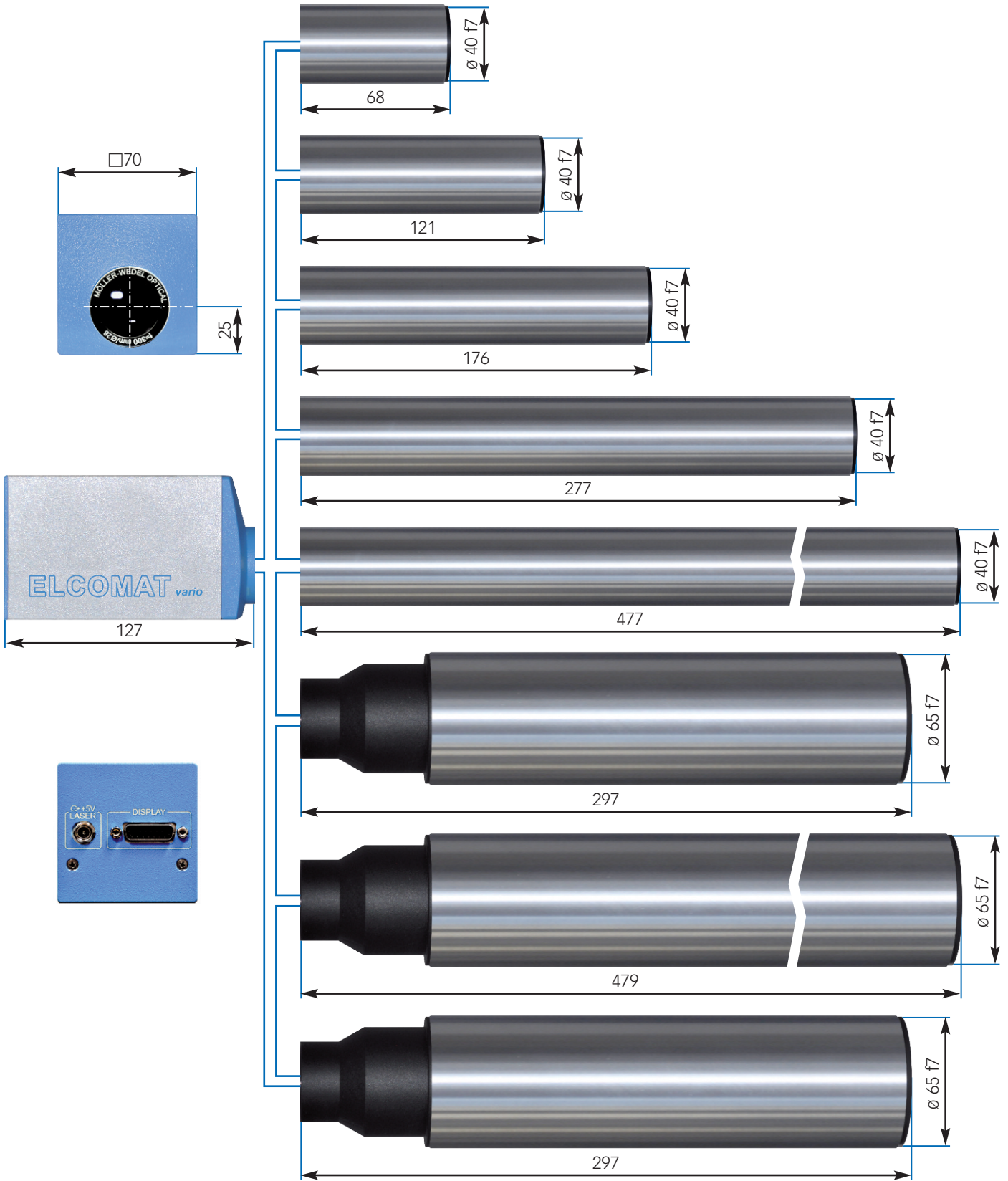

# ELCOMAT® vario N

## Functions of the Display Unit

### Selectable Display Modes/Functions

Display	Crosshair
Average	0.25 s
Distance	Short
Unit	arcsec
Resolution	0.001"
Tolerances	
Colors	Day
Remote	Save
USB / RS232	Text protocol
Sounds	Off
Language	English
Straightness	Crosshair
	Big numbers
	Data grid

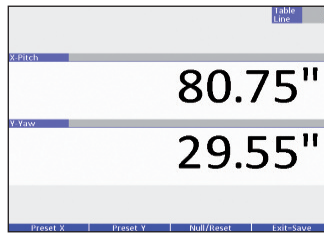
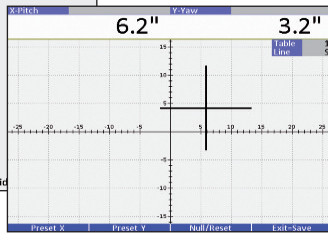

X Pitch	80.75"	Y Yaw	28.90"
Line	1	Line	9
1	25.65"	4.45"	
2	115.90"	77.60"	
3	12.25"	92.65"	
4	12.75"	94.65"	
5	6.90"	12.85"	
6	6.95"	12.60"	
7	38.55"	31.60"	
8	53.95"	41.45"	

Numerical Display (table)

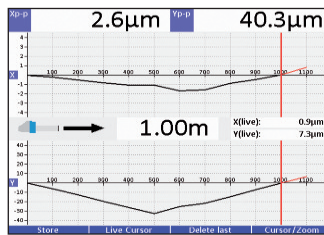

In addition to the well-known graphical, numerical and tabular display, the display unit has additional functions such as a practical "on-the-fly" straightness measurement.

### Angle Display in Different Angular Units of Measurement

Display	Big numbers
Average	0.25 s
Distance	Short
Unit	arcsec
Resolution	0.001"
Tolerances	
Colors	Day
Remote	Save
USB / RS232	Text protocol
Sounds	Off
Language	English
arcsec	degree
	deg'min'sec"
	millirad
	µm

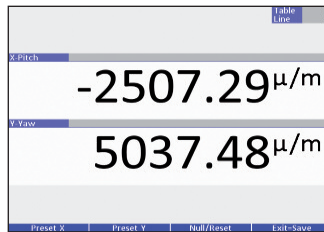
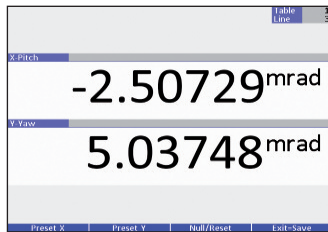
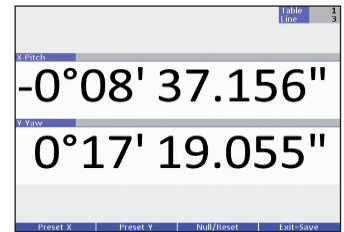
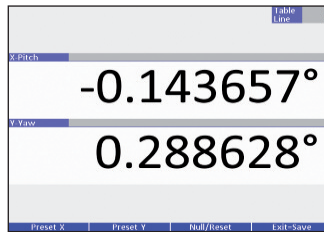
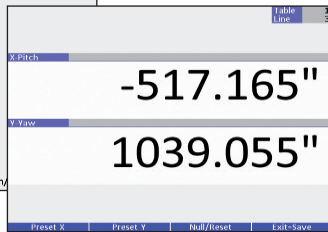

The display unit offers 5 selectable angular units.

### Resolution of the Measured Data Display in 12 Steps

Display	Big numbers
Average	0.25 s
Distance	Short
Unit	arcsec
Resolution	0.001"
Tolerances	
Colors	Day
Remote	Save
USB / RS232	Text protocol
Sounds	Off
Language	English
0.001"	0.002"
	0.005"
	0.01"
	0.02"
	0.05"
	0.1"
	0.2"

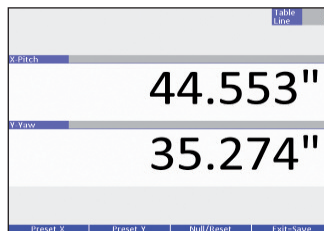
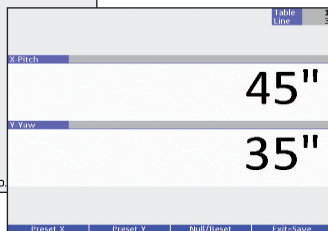

Display	Big numbers
Average	0.25 s
Distance	Short
Unit	arcsec
Resolution	0.005 µ/m
Tolerances	
Colors	Day
Remote	Save
USB / RS232	Text protocol
Sounds	Off
Language	English
0.005µ/m	0.01µ/m
	0.02µ/m
	0.05µ/m
	0.1µ/m

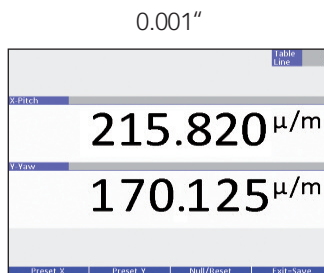
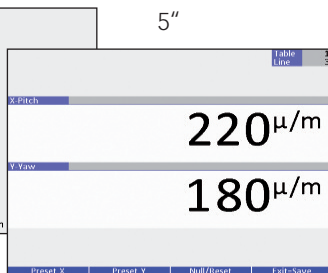

12 resolution levels are available for different measurement requirements.

arcsec"	Degree°	µm/m
5	0.001	20
2	0.0005	10
1	0.0002	5
0.5	0.0001	2
0.2	0.00005	1
0.1	0.00002	0.5
0.05	0.00001	0.2
0.02	0.000005	0.1
0.01	0.000002	0.05
0.005	0.000001	0.02
0.002	0.0000005	0.01
0.001	0.0000002	0.005

# ELCOMAT® vario N

## Functions of the Display Unit

### Digital Zoom

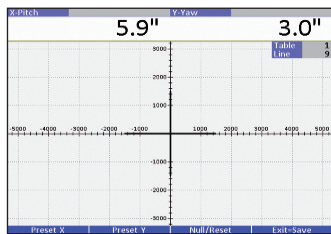

Display Area 5000'' x 3000''  
Interval 200''

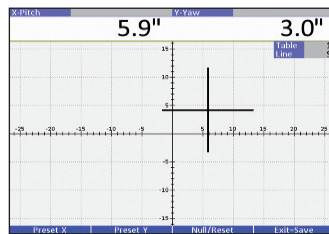

Display Area 25'' x 15''  
Interval 1''

Display Area arcsec''	Interval arcsec''
5000 x 3000	200
2500 x 1500	100
1250 x 750	50
500 x 300	20
250 x 150	10
125 x 75	5
50 x 30	2
25 x 15	1

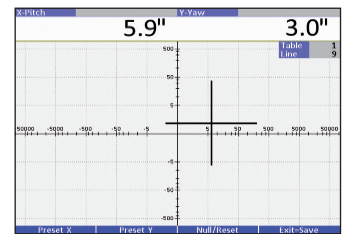

Logarithmic Scale

The display unit allows comfortable adjustment of the autocollimator or reflector by using 8 digital zoom levels or an additional display mode in logarithmic scale.

### Tolerances

Tolerancefield	Rectangular
Tolerance X	180.0''
Tolerance Y	180.0''

Input of tolerance limits and display of a rectangular tolerance field

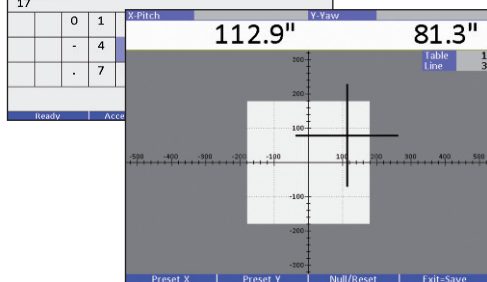

Tolerancefield	Circular
Tolerance R	200.0''

Input of tolerance limits and display of a circular tolerance field

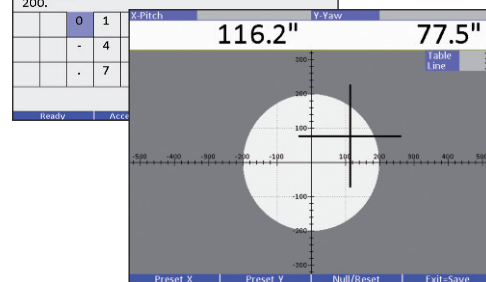

The graphical display of a rectangular or circular tolerance field allows a quick tolerance check. The size of the tolerance field is editable.

### Averaging

Display	Crosshair
Average	0.25 s
Distance	Short
Unit	arcsec
Resolution	0.001''
Tolerances	
Colors	Day
Remote	Save
USB / RS232	Text protocol
Sounds	Off
Language	English

Setting the averaging time only influences the display of the measured values in the display unit. With a low time value, fast measurement or adjustment is possible. If the signal-to-noise ratio is low, less noisy measured values can be displayed due to a longer averaging time.

### Distance

Display	Crosshair
Average	0.25 s
Distance	Short
Unit	arcsec
Resolution	0.001''
Tolerances	
Colors	Day
Remote	Save
USB / RS232	Text protocol
Sounds	Off
Language	English

Depending on the measuring task, it is possible to switch between distance mode (distance autocollimator-reflector) Short or Long. If Short is selected, a larger measuring range is available, but the measuring distance is limited.

If Long is selected, it is possible to measure at larger distances, but the measuring range is smaller than in the short mode.

The measuring ranges for the respective distance modes are given on pages 14/15.

# ELCOMAT® vario N

## Functions of the Display Unit

### Remote Control

Display	Crosshair
Average	0.25 s
Distance	Short
Unit	arcsec
Resolution	0.001"
Tolerances	
Colors	Day
Remote	Save
USB / RS232	Text protocol
Sounds	Off
Language	English
Ignore	Save Set/Reset

This function defines the commands for the IR remote control. The following settings are possible:

- Save
- Reset

### Alignment

Display	Alignment
Average	0.25 s
Distance	Short
Unit	arcsec
Resolution	0.001"
Tolerances	
Colors	Day
Remote	Save
USB / RS232	Text protocol
Sounds	Off
Language	English
Straightness	Crosshair Big num

With this function, the measuring sensor can be aligned to the earth axis (pitch, yaw, roll) without any further aids.

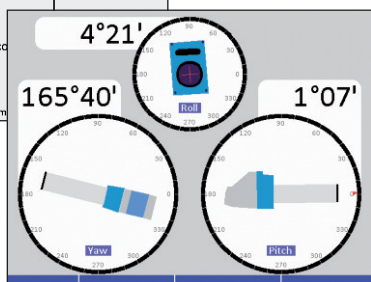

### Language Selection

Display	Crosshair
Average	0.25 s
Distance	Short
Unit	arcsec
Resolution	0.001"
Tolerances	
Colors	Day
Remote	Save
USB / RS232	Text protocol
Sounds	Off
Language	English
English	German

The display unit supports the following languages:

- German
- English

### Color Selection

Display	Crosshair
Average	0.25 s
Distance	Short
Unit	arcsec
Resolution	0.001"
Tolerances	
Colors	Day
Remote	Save
USB / RS232	Text protocol
Sounds	Off
Language	English
Day	Night

In addition to the well-known view (day mode), the view setting can be switched to night mode.

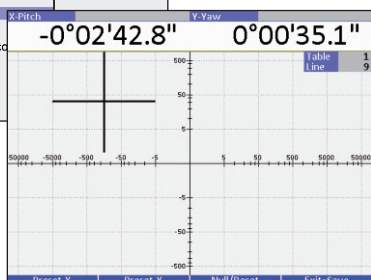

# ELCOMAT® vario N

## Typical applications

### Typical applications for the ELCOMAT® vario N product line are:

- Straightness, parallelism, tilt angle measurement
- Flatness measurement
- Rotatory position uncertainty measurement
- Squareness measurement
- Wobble measurement, adjustment of reflectors
- Calibration of angle measuring instruments
- Calibration of reference standards

### Straightness, Parallelism, Angle Tilting

Measurement of straightness, parallelism of guideways and measurement of angular tilting of a slide or deformation of machine parts (max. length depending on autocollimator type).

#### Recommended Accessories:

Art.No.: 223 056 or 223 057, 223 082\*,  
223 271, 219 757, 221 015\*,  
221 028\*, 219 735\*

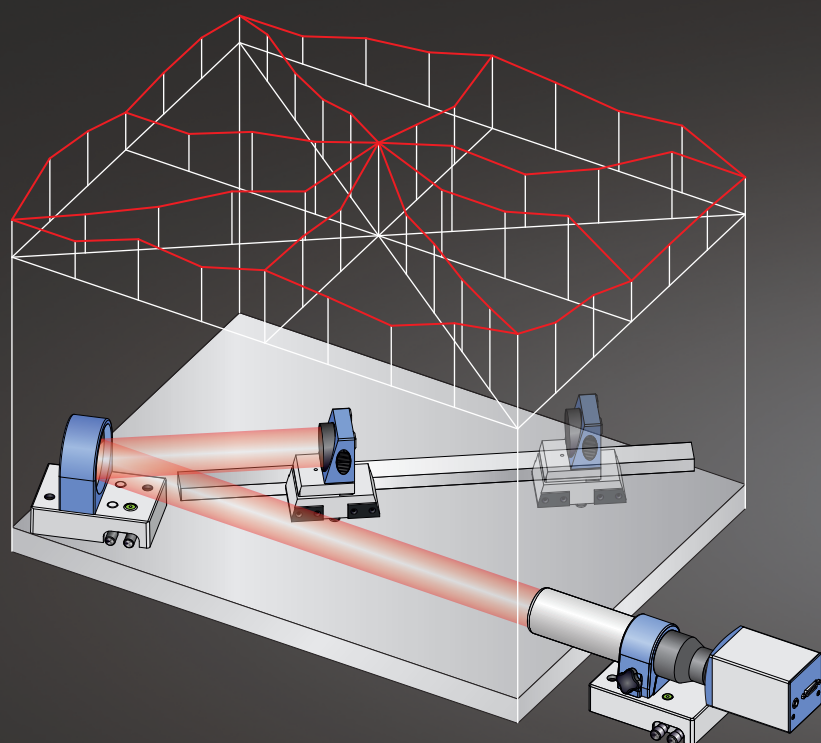
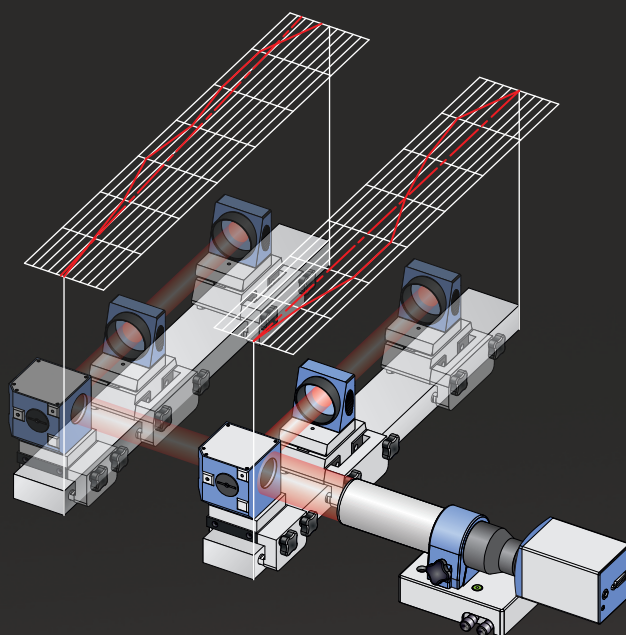

### Flatness

Flatness measurement of large, flat surfaces, e.g. stone plates, leveling plates and optical tables.

#### Recommended Accessories:

Art.No.: 223 056 or 223 057, 223 271,  
219 757, 223 221\*, 219 735\*



## Squareness

Measurement of the squareness from spindle axis to steady rest axis, from spindle stroke to machine bed and between guideways or of 90° stone-angle standards.

### Recommended Accessories:

Art.No.: 223 056 or 223 057, 223 082\*,  
223 271, 219 757, 221 015,  
221 028, 219 735\*

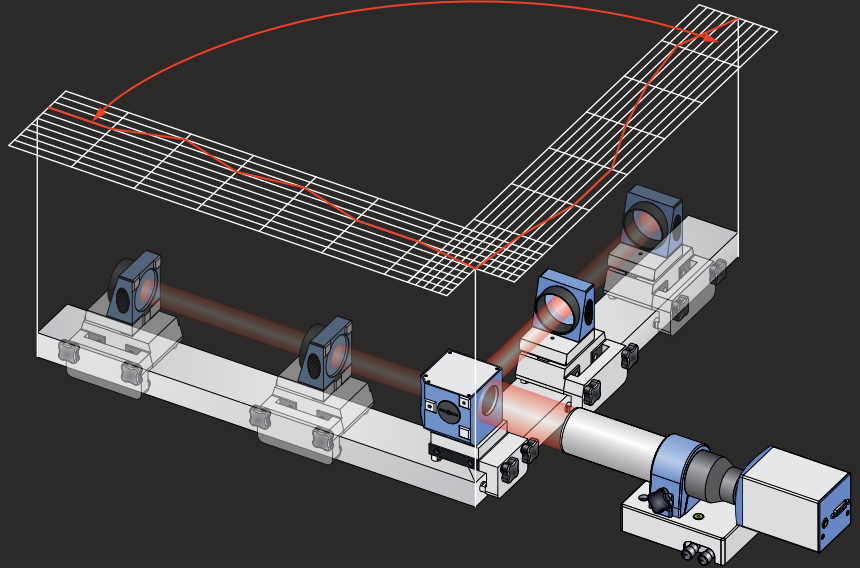

## Position Uncertainty

Determination of the position uncertainty of index tables and rotary tables as well as the absolute measurement of polygon mirrors.

### Recommended Accessories:

Art.No.: 223 056 or 233 057, 219 757,  
205 313 or 205 307, 219 742\*

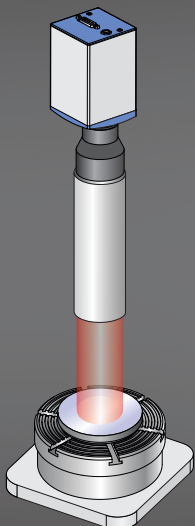
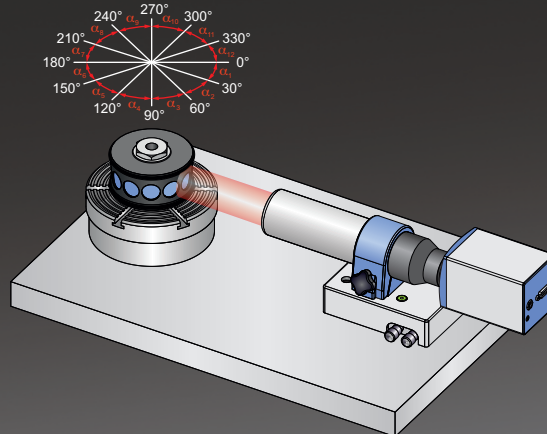

## Wobble, Alignment, Angle Measurement

Measurement of the wobble of bearings and rotary tables in reflection as well as wedge angle measurement in transmission against a mirror and alignment of optical components (e.g. mirrors), etc.

\* Optional accessories depending on the respective measuring task

# ELCOMAT® vario N

## Principle of Straightness/Flatness Measurement

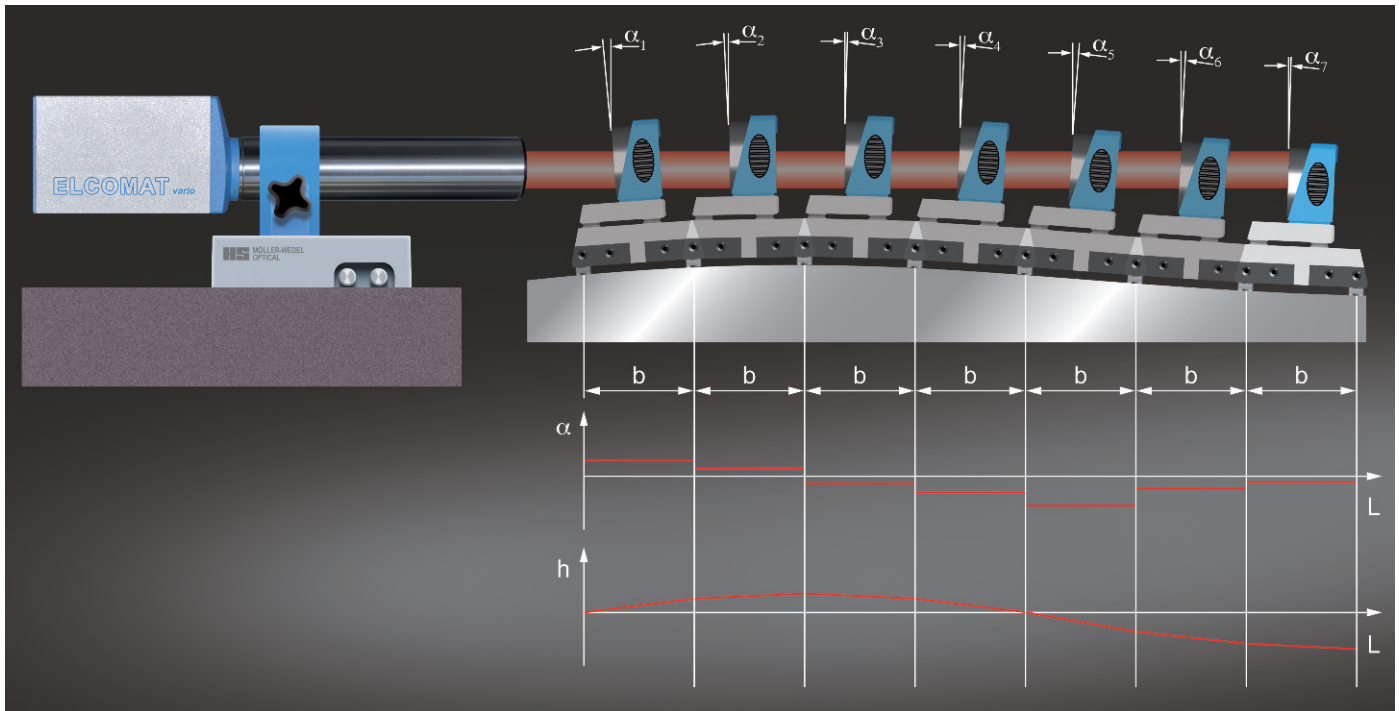

### Principle:

To measure straightness, the autocollimator is placed on a reference position to the guideway and the corresponding mirror with base and stop bar are placed on the guideway. When the mirror is shifted, any deviation of the straightness (horizontal/vertical) of the guideway surface leads to a shift of the autocollimation image. To measure the lateral and height deviation of the guide, the mirror with base and stop bar is moved step by step by a corresponding base length (standard 50 or 100 mm) in the direction of measurement to determine the corresponding slope  $m$  ( $m_{x,y} \approx \Delta\alpha_{x,y}$ ). The height or side deviation results from the product of the local slope  $m$  and the base length of the mirror  $b$ .

### Function Straightness in Display Unit:

The special feature of the easy-to-use straightness measurement function in the display unit is that it displays the profile directly after the measured value has been recorded and is also able to calculate the effects of individual changes to certain measuring positions on the entire measuring path. This eliminates the need for time-consuming re-measurement of the entire measuring path and the operator can correct measuring points "on-the-fly" using the overwrite function. The cursor function can also be used to simulate the influence of changes on the curve profile, for example before scarring or straightening.

For more comprehensive evaluation, logging and protocol management the proven [ELCOWIN](#) software can be used.

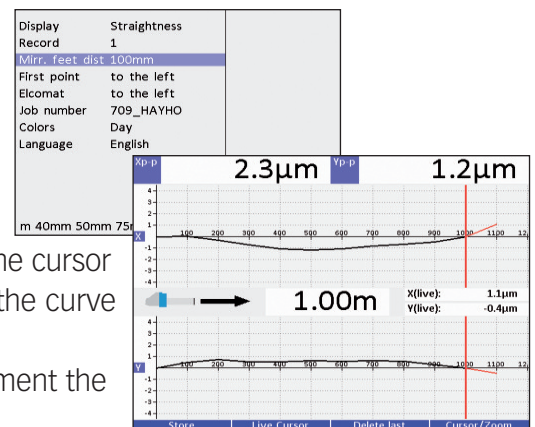

# ELCOMAT® vario N Software

## INCOLINK

Software interface for transfer of measurement data from ELCOMAT® vario N to computer

- Time-controlled recording of measured values
- Simple integration of the measured values via the clipboard into the customer's own software (e.g. Excel®).

Note: Runs under Windows®.

The INCOLINK software is always included in the scope of delivery of the ELCOMAT® vario.

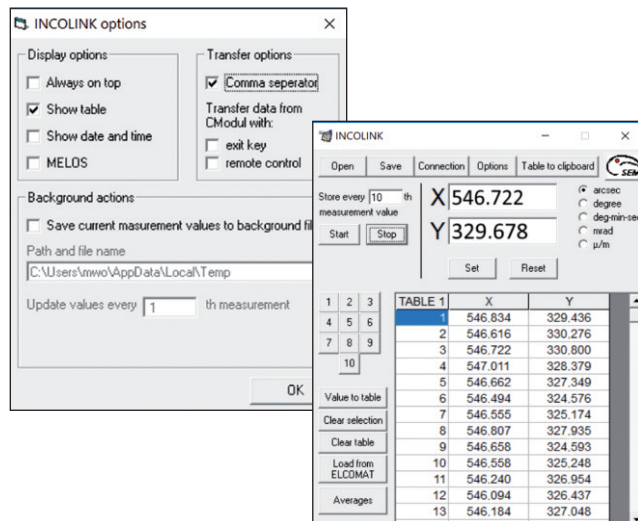

Description	Comment	Art. No.
INCOLINK	In scope of delivery	219 739

## ELCOWIN

ELCOWIN software for evaluation of straightness, squareness, parallelism of guideways and flatness of measuring plates and tables

- Automatic transfer of the ELCOMAT® vario N measurement data to the software
- Simultaneous acquisition of the measured values of both measuring axes (horizontal/vertical)
- Optional: manual data input

Note: Runs under Windows®.

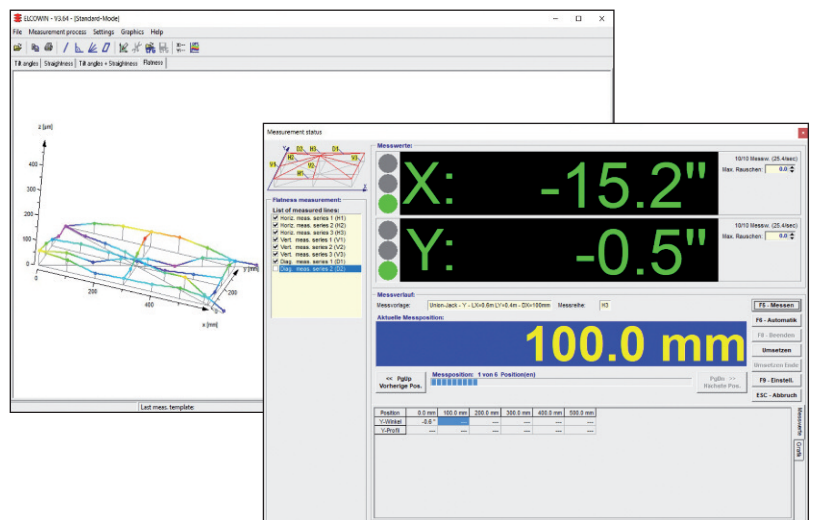

Description	Comment	Art. No.
ELCOWIN	Language English	219 736

## RTM

Software RTM for determination of position uncertainty/positioning accuracy of rotary tables/index tables according to VDI/DGQ 3441, VDI 2617, ISO 230-2

- Consideration of the angle errors of the angle standards used (polygon mirrors) in the calculation of the division positioning uncertainty error

Note: Runs under Windows®.



Description	Comment	Art. No.
RTM	Language English	219 743

# ELCOMAT® vario N

## Optional accessories

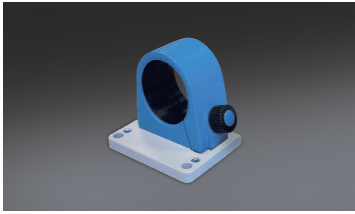

### Clamp Fixture

For integration of the ELCOMAT® vario N into existing set-ups  
 Height of optical axis: 62 mm  
 Mounting: 4 x M6 screws

Description	Art. No.
Clamp fixture D65	223 037
Clamp fixture D40	223 035

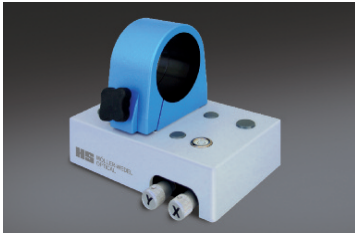

### Adjustable Holder (±2°)

For mounting of the ELCOMAT® vario N and for mounting on a tripod (Art.-No. 223 082)  
 Adjustment range (x,y): ±2°  
 Height of optical axis: 100 mm

Description	Art. No.
Adjustable holder D65	223 056
Adjustable holder D40	223 057

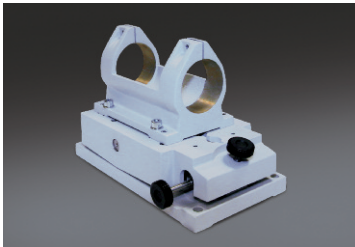

### Adjustable Holder (±4°)

For mounting of the ELCOMAT® vario N with increased demand on stability and for mounting on a tripod (Art.-No. 223 081)  
 Adjustment range (x,y): ±4°  
 Height of optical axis: 132 mm

Description	Art. No.
Adjustable holder with clamp fixture, double-sided D65	223 024
Adjustable holder with clamp fixture, double-sided D40	223 023



### Tripod

Enables flexible use and quick change of measuring position due to short set-up and dismantling times  
 Height: min. 630 mm, max. 1320 mm

Description	Art. No.
Tripod for adjustable holder 223 024 and 223 023	223 081
Tripod for adjustable holder 223 056 and 223 057	223 082

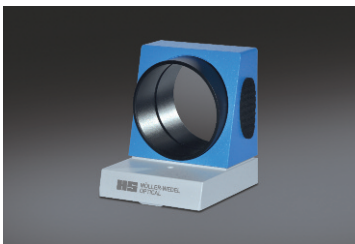

### Mirror in Mount

Ideal for measuring straightness, squareness, parallelism and flatness  
 Height of optical axis: 55 mm

Description	Art. No.
Mirror in mount, one-sided	223 260
Mirror in mount, double-sided	223 262

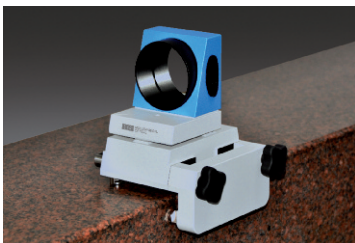

### Base with Stop Bar

For the mounting of the mirrors in mount (Art. No. 223 260, 223 262), base length of 50 or 100 mm as well as precise guidance through removable stop bar  
 Height of optical axis: 100 mm (incl. mirror)

Description	Art. No.
Base 100	223 264
Stop bar for base 100	223 269
Base mirror, complete (223 262 + 223 264 + 223 269)	223 271

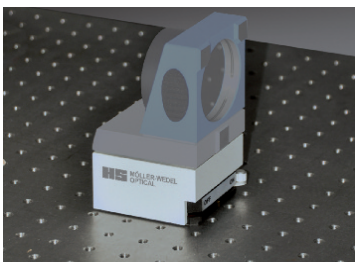

### Magnetic Base

For mounting mirrors in mounts to any magnetic surfaces  
 Height of optical axis: 100 mm (incl. mirror)

Description	Art. No.
Magnetic base for mirror additionally required:	223 282
Mirror in mount, one-sided	223 260
or	
Mirror in mount, double-sided	223 262

Description	Art. No.
Mirror D100, adjustable, double-sided	223 221

### Mirror D100, adjustable

For use as auxiliary or turning mirror  
Adjustment range  $\pm 2^\circ$  in both axes  
Height of optical axis: approx. 100 mm

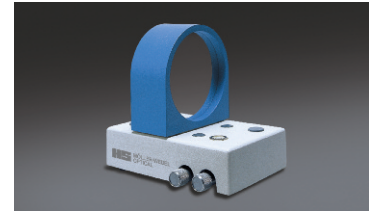

Description	Art. No.
Laser Attachment D65	219 757
Laser Attachment D40	219 767

### Laser Attachment

For quick and easy alignment of the ELCOMAT®vario N to a target reflector

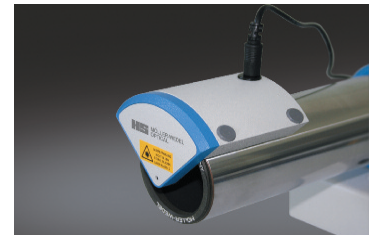

Description	Art. No.
Pentaprism 2" in mount	221 015
Pentaprism 2" with wedge in mount	221 016

### Pentaprism in Mount

Extension for measurement of squareness and parallelism

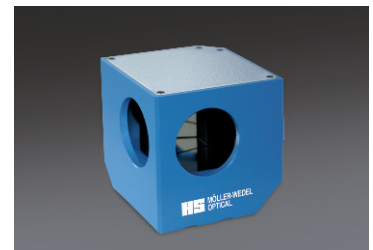

Description	Art. No.
Base for Pentaprism in mount with stop bar	221 028

### Base for Pentaprism in Mount

For mounting of the pentaprism in mount (Art. No. 221 015, 221 016) with removable stop bar for precise positioning  
Height of optical axis: 100 mm

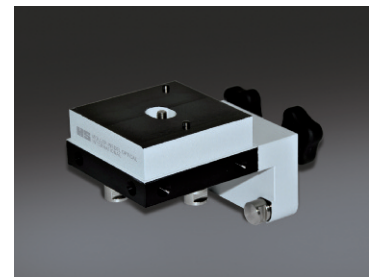

Description	Art. No.
Holder D65 for Pentaprism	221 023

### Holder for Pentaprism

For mounting the pentaprism in mount (Art. No. 221 015, 221 016) to the objective tube D65 of for measurement of squareness

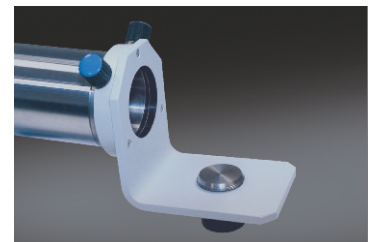

Description	Art. No.
Polygon Mirror 12 Surfaces 2"	205 313
Polygon Mirror 8 Surfaces 2"	205 307

### Polygon Mirror

Angular measuring standard for the measurement of the rotatory position uncertainty of index or rotary tables  
Mirror:  $\varnothing$  38 mm (8 surfaces)  
 $\varnothing$  25 mm (12 surfaces)



Description	Art. No.
Autocollimator Test-Wedge	223 244

### Autocollimator Test-Wedge

Autocollimator test-wedge for quick testing of autocollimators.

The test-wedge is certified and allows on-site testing of angular accuracy.

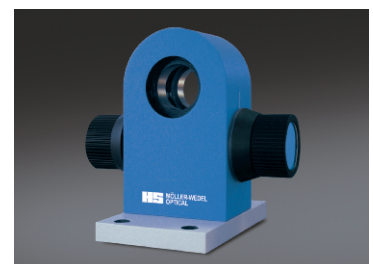

# ELCOMAT® vario N

## Technical data

		<b>ELCOMAT® vario N 90/40</b>	<b>ELCOMAT® vario N 140/40</b>	<b>ELCOMAT® vario N 200/40</b>
<b>Art. No.</b>		<b>229 811</b>	<b>229 812</b>	<b>229 813</b>
Accuracy in	arcsec*	± 3	± 2	± 1.5
corresponds to	μ/m	± 15	± 10	± 7
Number of measuring axes		2	2	2
Supported measuring modes	short/long	2 (see ***)	2 (see ***)	2 (see ***)
Measuring range (short)		8170 x 6840 up to 0.2 m	5140 x 4320 up to 0.7 m	3560 x 2980 up to 1.0 m
wide measuring range		7090 x 6830 at 0.4 m	4960 x 4300 at 0.9 m	2390 x 2390 at 3.0 m
short measuring distance		5700 x 5700 at 0.6 m	3360 x 3360 at 2.0 m	
(X) x (Y), arcsec		1540 x 1490 at 0.8 m		
		1320 x 1280 at 1.0 m		
Measuring range (long)		6620 x 5300 up to 0.2 m	4000 x 3340 up to 0.7 m	2880 x 2300 up to 1.0 m
smaller measuring range		4200 x 4060 at 0.4 m	3190 x 3100 at 0.9 m	1030 x 1030 at 3.0 m
long measuring distance		2700 x 2650 at 0.6 m	1380 x 1380 at 2.0 m	460 x 460 at 5.0 m
(X) x (Y), arcsec		1540 x 1490 at 0.8 m	490 x 490 at 4.0 m	260 x 260 at 7.0 m
		1280 x 1280 at 1.0 m	240 x 240 at 6.0 m	200 x 200 at 8.0 m
		1020 x 1020 at 1.2 m		
		800 x 800 at 1.4 m		
Capture range	arcsec	corresponds to measuring range		
Resolution	arcsec	0.005 up to 10; adjustable, additional logarithmic display		
Reproducibility	arcsec	0.4	0.3	0.2
Focal length	mm	90	140	200
LED wavelength	nm	635	635	635
Minimum reflector size	mm			
R > 85% (mirror coated)		∅ 3	∅ 4	∅ 5
R ≈ 4% (uncoated glass)		∅ 4	∅ 5	∅ 6
Free opening	mm	16	28	28
Height of the optical axis	mm	100 (in adjustable holder 223 056 or 223 057) 62 (in clamp fixture 223 035 or 223 037)		
Computer interface		RS-232 / USB	RS-232 / USB	RS-232 / USB
Mains voltage	V / Hz	90...250 / 50...60	90...250 / 50...60	90...250 / 50...60
Dimensions	mm	195 x 70 x 70	248 x 70 x 70	303 x 70 x 70
autocollimation sensor				
Dimensions	mm	190 x 190 x 33	190 x 190 x 33	190 x 190 x 33
Display unit (without bracket)				
Tube diameter	mm	∅ 40 f7	∅ 40 f7	∅ 40 f7
Weight	kg	0.8	0.9	1.2
autocollimation sensor				
Weight	kg	0.7	0.7	0.7
Display unit				
Scope of delivery		Autocollimation sensor, display module, software INCOLINK, power supply, IR remote		

\* Measuring distance: 0.1m

\*\* Can be used in conjunction with an adapter for connection to an Ethernet interface.

\*\*\* In the display unit, depending on the application, you can choose between the "short" mode for an enlarged measuring range at short measuring distances or the "long" mode for

ELCOMAT® is a registered Union trademark (EUTM 018002083), Trade Mark in CN (Int. Reg. No. 1476462), U.S. Trade Mark (6,010,398), Trade Mark in JP (1476462).

<b>ELCOMAT® vario N 300/40 229 814</b>	<b>ELCOMAT® vario N 500/40 229 815</b>	<b>ELCOMAT® vario N 300/65 229 816</b>	<b>ELCOMAT® vario N 500/65 229 817</b>	<b>ELCOMAT® vario N 500T/65 229 818</b>
± 0.8	± 0.4	± 0.8	± 0.4	± 0.4
± 4	± 2	± 4	± 2	± 2
2	2	2	2	2
2 (see ***)	2 (see ***)	2 (see ***)	2 (see ***)	2 (see ***)
2380 x 2000 up to 1.0 m 2050 x 1990 at 3.0 m 1570 x 1570 at 5.0 m	1420 x 1200 up to 2.0 m 1330 x 1190 at 4.0 m 1030 x 1030 at 6.0 m	2380 x 2000 up to 3.0 m 2050 x 1980 at 5.0 m 1700 x 1700 at 7.0 m	1400 x 1200 up to 7.0 m 1360 x 1200 at 8.0 m 1180 x 1180 at 10.0 m	1400 x 1200 up to 7.0 m 1360 x 1200 at 8.0 m 1180 x 1180 at 10.0 m
1920 x 1540 up to 1.0 m 1100 x 1060 at 3.0 m 650 x 650 at 5.0 m 360 x 360 at 7.0 m 240 x 240 at 9.0 m	1160 x 920 up to 2.0 m 800 x 800 at 4.0 m 510 x 510 at 6.0 m 360 x 360 at 8.0 m 230 x 230 at 10.0 m	1910 x 1530 up to 3.0 m 1130 x 1090 at 5.0 m 750 x 750 at 7.0 m 590 x 590 at 9.0 m 390 x 390 at 11.0 m 300 x 300 at 13.0 m	910 x 910 up to 7.0 m 800 x 800 at 8.0 m 610 x 610 at 10.0 m 500 x 500 at 12.0 m 410 x 410 at 14.0 m 360 x 360 at 16.0 m 270 x 270 at 18.0 m	910 x 910 up to 7.0 m 800 x 800 at 8.0 m 610 x 610 at 10.0 m 500 x 500 at 12.0 m 410 x 410 at 14.0 m 360 x 360 at 16.0 m 270 x 270 at 18.0 m
corresponds to measuring range				
0,005 up to 10; adjustable, additional logarithmic display				
0.1	0.05	0.1	0.05	0.05
300	500	300	500	500
635	635	635	635	635
∅ 5	∅ 6	∅ 6	∅ 6	∅ 8
∅ 6	∅ 7	∅ 7	∅ 7	∅ 9
28	28	50	50	50
100 (in adjustable holder 223 056 or 223 057) 62 (in clamp fixture 223 035 or 223 037)				
RS-232 / USB	RS-232 / USB	RS-232 / USB	RS-232 / USB	RS-232 / USB
90...250 / 50...60 404 x 70 x 70	90...250 / 50...60 604 x 70 x 70	90...250 / 50...60 424 x 70 x 70	90...250 / 50...60 606 x 70 x 70	90...250 / 50...60 424 x 70 x 70
190 x 190 x 33	190 x 190 x 33	190 x 190 x 33	190 x 190 x 33	190 x 190 x 33
∅ 40 f7	∅ 40 f7	∅ 65 f7	∅ 65 f7	∅ 65 f7
1.6	2.2	2.3	3.5	3.4
0.7	0.7	0.7	0.7	0.7
control, RS-232 cable**, USB cable, transport and storage case				

a large measuring distance with good pre-alignment. It is not allowed to switch between the measuring modes during a measurement.

**MÖLLER-WEDEL OPTICAL GmbH**

Rosengarten 10  
D-22880 Wedel

Tel.: +49 - 41 03 - 9 37 76 10  
Fax: +49 - 41 03 - 9 37 76 60

[www.moeller-wedel-optical.com](http://www.moeller-wedel-optical.com)  
e-mail: [info@moeller-wedel-optical.com](mailto:info@moeller-wedel-optical.com)